

UNDERGROUND MINING

As a recognized leader in custom engineered underground ropes, WRI has decades of experience in supplying some of the world's deepest mines with the harshest operating conditions. Our product range is unmatched in the industry, as is our capability to design the best rope for any application.

Through innovation, Wire Rope Industries goes beyond offering rope constructions traditionally supplied by our competitors. We strive to develop new designs which combine the benefits of existing types without the inherent downsides. We listened to our clients and created Cushion-Pac 35™, a revolutionary new hoist rope that has become an instant success in the underground mining market.



Talk to our experts and let us show you how our expertise and industry-leading products can help you reach new levels of productivity and profitability.



WIRE ROPE
INDUSTRIES

PRODUCT SELECTOR

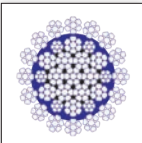
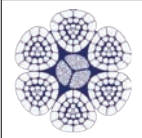
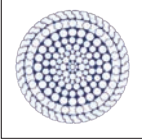
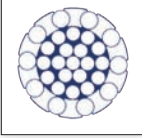
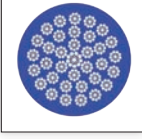
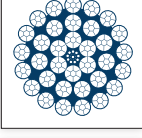
APPLICATION SELECTOR

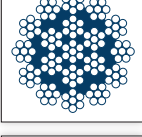
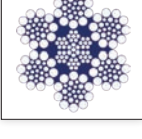
PRODUCTS		FRICITION HOIST	DRUM HOIST	BALANCE	GUIDE	SHAFT SINKING
Premium Ropes	 Cushion-Pac 35	<input checked="" type="checkbox"/>	<input checked="" type="checkbox"/>	<input type="checkbox"/>	<input type="checkbox"/>	<input checked="" type="checkbox"/>
	 Tri-Pac & Tri-Max	<input checked="" type="checkbox"/>	<input checked="" type="checkbox"/>	<input type="checkbox"/>	<input type="checkbox"/>	<input type="checkbox"/>
	 Power-Loc FLC	<input checked="" type="checkbox"/>	<input type="checkbox"/>	<input type="checkbox"/>	<input type="checkbox"/>	<input checked="" type="checkbox"/>
	 Power-Loc HLC	<input type="checkbox"/>	<input type="checkbox"/>	<input type="checkbox"/>	<input checked="" type="checkbox"/>	<input type="checkbox"/>
	 Cushion 34	<input type="checkbox"/>	<input type="checkbox"/>	<input checked="" type="checkbox"/>	<input type="checkbox"/>	<input type="checkbox"/>
	 DyPac 34	<input checked="" type="checkbox"/>	<input checked="" type="checkbox"/>	<input checked="" type="checkbox"/>	<input type="checkbox"/>	<input checked="" type="checkbox"/>
Standard Ropes	 PS 3410	<input checked="" type="checkbox"/>	<input checked="" type="checkbox"/>	<input checked="" type="checkbox"/>	<input type="checkbox"/>	<input checked="" type="checkbox"/>
	 PS 1810	<input checked="" type="checkbox"/>	<input checked="" type="checkbox"/>	<input checked="" type="checkbox"/>	<input type="checkbox"/>	<input checked="" type="checkbox"/>
	 PS 620	<input checked="" type="checkbox"/>	<input checked="" type="checkbox"/>	<input type="checkbox"/>	<input type="checkbox"/>	<input type="checkbox"/>

Ground Mounted Friction Hoist

2 Hoist Ropes ∇ 2 Balance Ropes

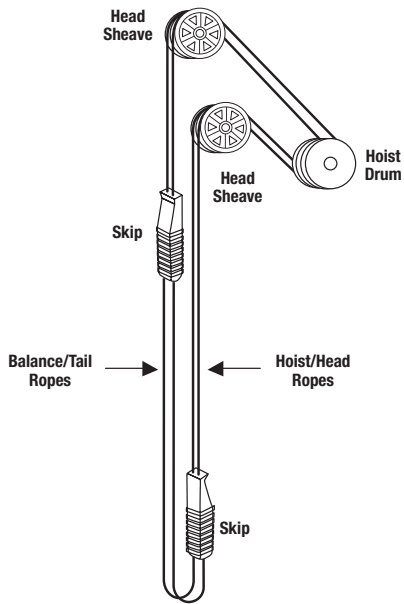

Tower Mounted Friction Hoist with Deflectors

4 Hoist Ropes ∇ 2 Balance Ropes

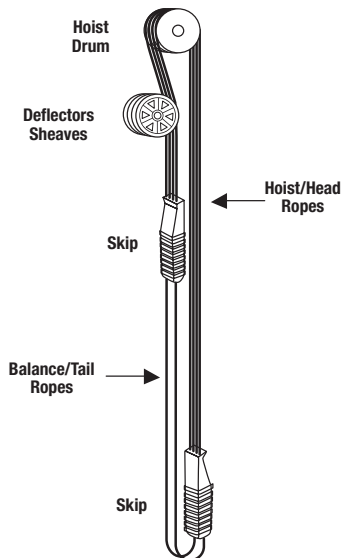

SHAFT SINKING

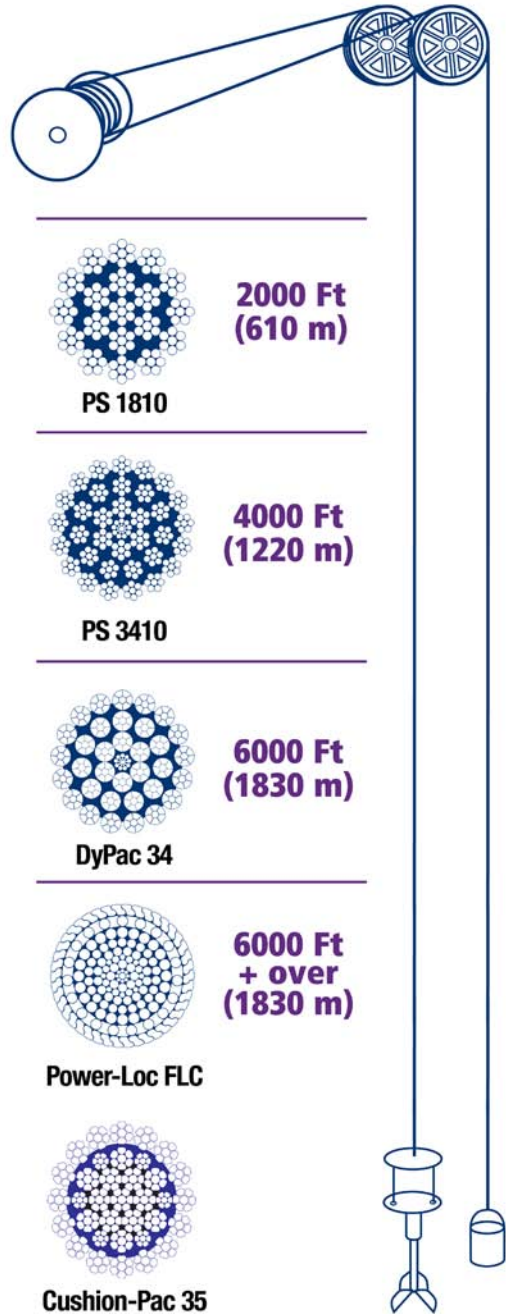

CUSHION-PAC 35™



New Rotation-Resistant Friction (Koepe) Hoist Rope

WRI's latest product combines the flexibility of triangular flattened strand ropes with non-rotational resistance required for installation in deep shafts which was until now only available with full-lock coil construction. The result has redefined our clients' expectations with the most versatile hoisting rope on the market.

Rotation Resistant

- » Rotation resistance allows the Cushion-Pac 35 to be used in modern deep shaft mines
- » Low torque means easier handling during installation and maintenance

Flexibility

- » More flexible than full-lock coil ropes
- » Less susceptible to structural upset

Minimal Elongation

- » The parallel lay construction of the core coupled with the compacting of the outer strands give the Cushion-Pac 35 a very high metallic area, which keeps the elongation to a minimum

Compacted Outer Strands

- » Increased breaking load and fatigue life
- » Smooth outer surface provides larger contact area with drum & sheaves for increased wear resistance and superior traction
- » Is compatible with existing polyurethane liners

Plastic Jacketed Core

- » A physical separation between the outer strands and the core that effectively seals in the core lubricant and ensures the proper positioning of the outer strands

Superior Lubrication

- » Outer strand lubricant is specifically formulated for Koepe friction winder applications
- » Core lubricant offers optimal protection against steel-to-steel abrasion for superior fatigue life

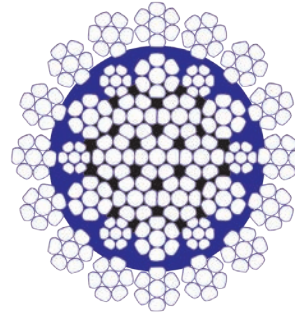

TRI-MAX FS™ & TRI-PAC FS™

Triangular Flattened Strand Hoist Ropes

- » A well-proven 6x27 lang-lay flattened triangular strand construction provides 2.5 times the contact area of a round strand rope.
- » Designed for increased rope strength, wear resistance and fatigue life, and exceptional resistance to drum crushing.
- » The (3/3) triangular strand center construction provides the best strength/performance combination for drums with a recommended D/d ratio of 80/1.
- » An optional (6/1) brangle strand center construction provides improved flexibility and fatigue life on drums with smaller D/d ratios.
- » Custom design capabilities and a full wire tensile range from 1770MPa (115 Long Tons/In²) to 2160 MPa (140 Long Tons/In²) ensure that rope can be designed to meet individual customer requirements.
- » A specially manufactured core increases rope life by significantly reducing stretch, providing a more consistent density and diameter to support the strands, resisting strand abrasion, and eliminating core rot caused by corrosive environments.
- » Specially formulated lubrication increases rope performance, reduces corrosion and other effects of shaft environments, and minimizes environmental impact due to fly-off.

How Tri-Max™ ropes reduce downtime and create value:

- » Greater rope contact area provides for smoother operation and reduced sheave and drum wear. The optional thermal plastic enhancement of the rope drum end significantly enhances protection of the dead wraps, improves support of the upper layers of rope.
- » Reduces stretch, and limits the number of drum end cuts required. Available high-quality conveyance attachments simplify installation and removal for rope test cuts, ensure maximum rope breaking-load efficiency, and reduce maintenance downtime.
- » Reduction of overall operating costs as a result of improved rope performance and maximized payloads
- » Reduction of equipment downtime due to quicker maintenance turnaround and fewer drum end cuts.

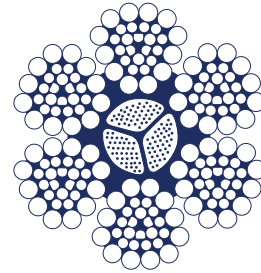

Tri-Max FS™

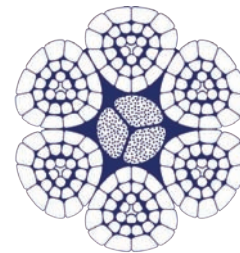

Tri-Pac FS™

PRODUCT OVERVIEWS

POWER-LOC FLC™

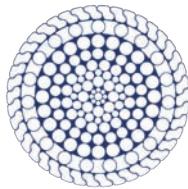

Full-lock coil ropes for friction (Koepe) hoisting applications:

- » A specialized full locked coil design, developed by WRI, provides one of the highest strength to weight ratios of any rope
- » Significantly increased cycle life, and reduced stretch compared to round or flattened triangular strand ropes. Power-Loc FLC™ is most effective when installed with a D/d ratio greater than 100-1.
- » Exclusive manufacturing techniques provide superior rotation resistance and virtually eliminate the natural torque and rotation common to round or flattened triangular strand ropes.
- » Custom design capabilities and the highest wire tensile range currently available ensure that production capacity can be maximized for each individual hoisting system.
- » Specially formulated lubrication maintains friction while increasing rope performance, thus reducing corrosion and other effects of shaft environments. The locked coil design has the added advantage of maintaining lubrication inside the rope.
- » Greater rope contact area and minimal rotation during hoisting provides smoother conveyance operation and reduces drum wear
- » Good correlation between loss in strength and loss in metallic area during EM testing makes it easier to determine the duration of rope life and to better plan change-outs
- » Available high-quality conveyance attachments simplify installation and removal for rope test cuts, ensure maximum rope breaking-load efficiency, and reduce maintenance downtime.

How Power-Loc FLC™ creates value:

- » Reduced overall operating costs as a result of significantly enhanced rope performance and maximized payloads.
- » Reduced equipment downtime due to fewer scheduled change-outs.
- » Reduced equipment maintenance costs resulting from less drum liner wear and smoother conveyance operation.

POWER-LOC HLC™

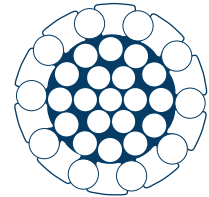

Half-lock coil ropes for Guide and Rubbing applications

WRI's Power-Loc HLC™ guide and rubbing ropes have two decades of proven track record.

- » A specially designed half locked coil construction provides excellent rotation resistance, superior wear properties and minimal movement in the shaft when compared to other rope constructions.
- » Locked coil rope guides provide a cost-effective alternative to rigid wood or metal guides by allowing for reduced shaft sizes and structures, improved air displacement on moving conveyances and minimized damage and wear caused by vibration.
- » WRI's recommended 9 pair outer wire rope design has less torque and rotation, and is easier to install when compared to 7 pair rope designs.
- » The smooth outer profile of the rope minimizes vibration, reduces conveyance slipper wear, and provides superior rope performance.
- » Specially formulated lubrication and recommended maintenance programs extend service life and reduce the corrosive effects of shaft environments.
- » Optional galvanizing further enhances corrosion resistance and service life. Galvanizing is recommended for the most severe shaft conditions.
- » High-quality positioning and suspension attachments, long established installation procedures, and qualified WRI technical personnel ensure efficient handling and minimized downtime.

How Power-Loc HLC™ creates value:

- » Reduced long-term operating costs as the result of increased service life and trouble-free operation
- » Reduced equipment wear and smoother conveyance operation resulting in lower maintenance costs

CUSHION 34™



Plasticized multi-strand ropes for balance applications

- » A 34x19 construction provides improved flexibility and an approximate natural loop to rope ratio of 50-1.
- » Multi-strand spin resistance and plastic enhancement allow for smooth in-service operation, significantly reduced rope torque and stretch, and less movement in the shaft when the rope is at full speed.
- » Full plastic impregnation improves spin-resistance and eliminates internal cross cutting of the strands which is common to other multi-strand products, thereby extending service life and improving security.
- » Galvanized wire and WRI's patented one-step impregnation and jacketing process, which provides a thick protective outer layer of plastic, prevents contaminants from corroding the rope and eliminates the need for costly in-field lubrication.
- » A smooth outer rope profile reduces the chance of entanglement and virtually eliminates dirt buildup, thereby maintaining a more constant T1/T2 ratio. Computer-designed custom ropes ensure accurate rope weights which meet specified T1/T2 ratios.
- » Factory installed sockets are also available

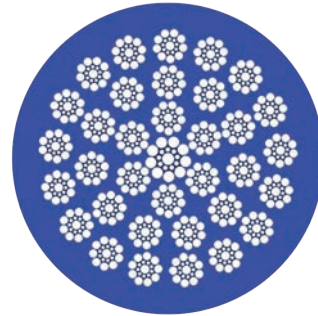

How Cushion 34™ creates value:

- » Reduced overall operating costs as the result of enhanced performance and the elimination of in-field lubrication.
- » Reduced equipment downtime resulting from fewer maintenance requirements.
- » Factory installed sockets dramatically reduce installation time on site



DYPAC 34

Premium version of PS3410 design

Dy-Pac® strand enhancement of a 34x7 (LCD) construction provides additional performance, an increase in strength of approximately 15%, reduced sheave and drum wear, and significantly enhanced drum spooling. As a result, operating depths can be extended up to approximately 6000 ft (1830 m).

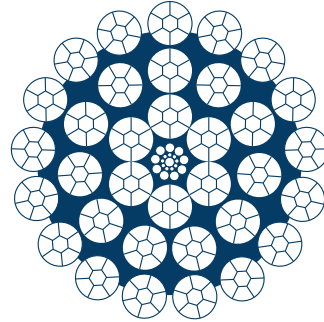

PS 3410

Standard rope for shaft sinking, hoisting, and balance applications

- » A well-proven 34x7 construction provides good flexibility
- » Multi-strand spin resistance allows for smoother in-service operation, reduced rope torque, and less movement in the shaft.
- » A specialized Line Contact Design (LCD) improves performance and reduces internal cross cutting damage, common to other multi-strand products. By combining outer langs-lay strands with inner regular lay strands, the underside of the outer strand wires run in the same direction as the wires of the supporting layer.
- » A specially manufactured core improves rope performance by reducing stretch, providing a more consistent density and diameter to support the strands, resisting strand abrasion, and eliminating core rot caused by corrosive environments.
- » Specially formulated lubrication extends service life by reducing corrosion and other effects of shaft environments.

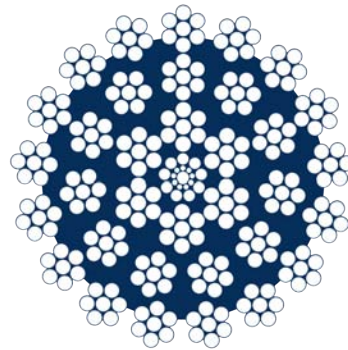

How PS 3410 creates value:

- » Reduced overall operating costs as the result of a high performance, cost effective rope design.
- » Reduced equipment downtime as the result of consistent trouble-free operation.

PS 1810

Standard rope for hoisting, balance, or shaft sinking applications

- » A resilient 18x7 IWRC construction and wire tensiles ranging from In2 1770 MPa (115 Long Tons/) to 2000 MPa (130 Long Tons/ In²) provide the necessary strength and reliability to operate up to depths of approximately 2000 ft (610 m).
- » A specialized Line Contact Design (LCD) improves performance and reduces internal cross cutting damage, common to other multi-strand products. By combining outer lang's lay strands with inner regular lay strands, the underside of the outer strand wires run in the same direction as the wires of the supporting layer.
- » Specially formulated lubrication increases rope performance and reduces the corrosive effects of shaft environments.

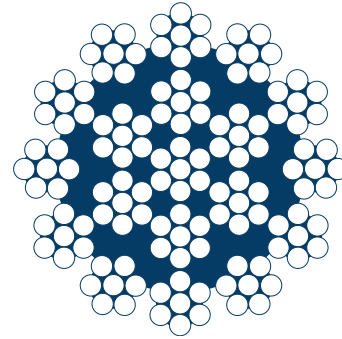

PS 620

Standard rope for low-depth hoisting applications

- » Specially selected wire tensile grades and 6 strand construction enhance wear resistance.
- » Specially formulated lubrication enhances wear properties, increases rope performance, and reduces environmental impact due to fly-off and the calibrated cut lengths and custom pad eyes simplify installation and reduce down-time.
- » Excellent value for less demanding applications

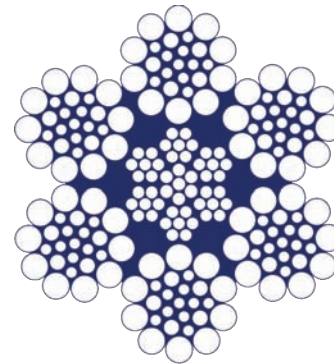

BEZINAL® 3000

BEZINAL® 3000 COATINGS



Developed by our parent company Bekaert, world leader in wire technology, Bezinal® is the next generation of Zinc-Aluminum coating for high-carbon wires.

We offer Bezinal for all our underground mining ropes. Bezinal coated ropes have been used by several of our flagship clients with exceptional results.

Benefits

- » Superior corrosion resistance for longer lifetime
- » Exposure up to 350°C leaves the coating intact
- » Cathodic protection
- » Active protection of cut ends
- » Sustained corrosion protection at welded points
- » Good formability
- » Withstands heavy deformations
- » Suitable for cycled fatigue loads

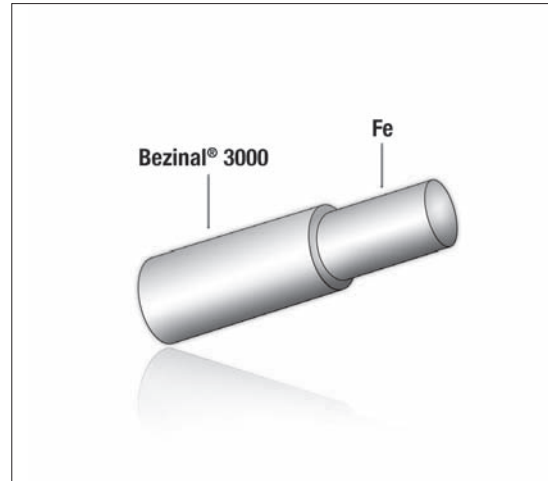

Bezinal® outperforms standard galvanized products by a least 3 to 1 (for the same coating weight) in many applications.

Salt Spray Performance

(hours exposure before appearance of 5% Dark Brown Rust (DBR);

Redrawn wires Bezinal® 3000
Class B according to EN-10244-2

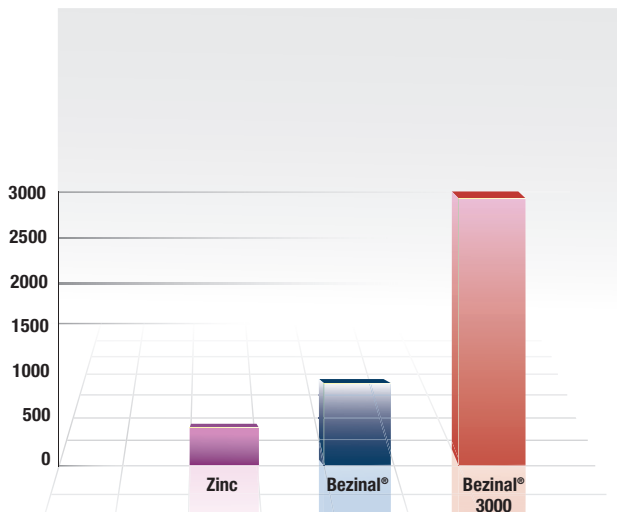

Final coated wires Bezinal® 3000
Class A according to EN-10244-2

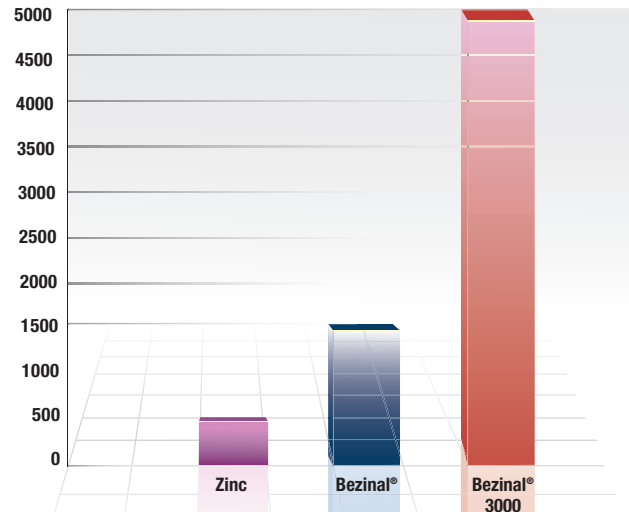

PRODUCT SPECIFICATIONS

BREAKING LOAD TABLES - UNDERGROUND MINING



Tri-MAX FS™

DIAMETER		CONSTRUCTION	APPROX. WEIGHT		MINIMUM BREAKING LOAD									
inches	mm		lb/ft	kg/m	Gr 115		Gr 120		Gr 125		Gr 133		Gr 140	
					Tons	kN	Tons	kN	Tons	kN	Tons	kN	Tons	kN
7/8	22	6x27 (3/3) LL Polyester Core	1.33	1.98	35.6	317	37.1	330	39.0	347	41.2	367	43.2	385
1	25	6x27 (3/3) LL Polyester Core	1.74	2.59	47.0	419	48.9	435	51.3	457	54.4	484	57.5	512
1 1/8	29	6x27 (3/3) LL Polyester Core	2.22	3.30	59.9	533	62.7	558	65.1	579	69.2	616	73.2	651
1 1/4	32	6x27 (3/3) LL Polyester Core	2.74	4.08	74.1	660	77.4	689	80.3	714	85.7	763	90.3	803
1 3/8	35	6x27 (3/3) LL Polyester Core	3.32	4.94	89.8	799	93.6	833	97.4	867	104	924	108	960
1 1/2	38	6x27 (3/3) LL Polyester Core	3.95	5.88	107	951	112	993	116	1,036	124	1,100		-
1 5/8	41	6x27 (3/3) LL Polyester Core	4.66	6.93	126	1,120	131	1,167	137	1,218	146	1,296		-
1 3/4	44	6x27 (3/3) LL Polyester Core	5.37	7.99	145	1,294	152	1,349	158	1,404	168	1,496		-
1 7/8	48	6x27 (3/3) LL Polyester Core	6.09	9.06	165	1,471	172	1,535	180	1,602	191	1,701		-
2	51	6x27 (3/3) LL Polyester Core	6.90	10.27	187	1,666	195	1,737	203	1,809	216	1,926		-
2 1/8	54	6x27 (3/3) LL Polyester Core	7.80	11.61	211	1,877	220	1,957	229	2,042	244	2,171		-
2 1/4	57	6x27 (3/3) LL Polyester Core	8.55	12.72	237	2,105	247	2,198	252	2,241	274	2,435		-

Note: For 6x25 (6/1) brangle and 6x30 style "G" flattened (triangular) strand ropes, reduce the minimum breaking load by 5%.

PRODUCT SPECIFICATIONS

BREAKING LOAD TABLES - UNDERGROUND MINING

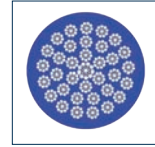

Cushion 34 Balance Ropes

DIAMETER		CONSTRUCTION	APPROX. WEIGHT		MINIMUM BREAKING LOAD					
inches	mm		lb/ft	kg/m	Gr 90		Gr 100		Gr 110	
					Tons	kN	Tons	kN	Tons	kN
3/4	19.1	34x19 RRL Gal IWRC Cushion Rope	1.5	2.2	25.5	227	28.3	252	31.2	278
7/8	22.2	34x19 RRL Gal IWRC Cushion Rope	1.8	2.6	30.8	274	34.2	304	37.6	335
1	25.4	34x19 RRL Gal IWRC Cushion Rope	2.1	3.1	36.9	329	41.0	365	45.1	402
1 1/8	28.6	34x19 RRL Gal IWRC Cushion Rope	2.6	3.8	44.8	399	49.8	443	54.8	488
1 1/4	31.8	34x19 RRL Gal IWRC Cushion Rope	3.1	4.7	56.2	501	62.5	556	68.7	612
1 3/8	34.9	34x19 RRL Gal IWRC Cushion Rope	3.8	5.7	66.8	594	74.2	660	81.6	726
1 1/2	38.1	34x19 RRL Gal IWRC Cushion Rope	4.5	6.7	79.6	709	88.5	787	97.3	866
1 5/8	41.3	34x19 RRL Gal IWRC Cushion Rope	5.4	8.0	94.4	840	104.9	933	115.4	1,027
1 3/4	44.5	34x19 RRL Gal IWRC Cushion Rope	6.3	9.3	110	981	122.4	1,090	134.7	1,199
1 7/8	47.6	34x19 RRL Gal IWRC Cushion Rope	7.2	10.8	127	1,131	141.2	1,256	155.3	1,382
2	50.8	34x19 RRL Gal IWRC Cushion Rope	8.2	12.1	143	1,275	159.2	1,417	175.1	1,558
2 1/8	54.0	34x19 RRL Gal IWRC Cushion Rope	9.2	13.7	162	1,439	179.7	1,599	197.6	1,759
2 1/4	57.2	34x19 RRL Gal IWRC Cushion Rope	10.3	15.3	181	1,606	200.6	1,785	220.6	1,963
2 3/8	60.3	34x19 RRL Gal IWRC Cushion Rope	11.3	16.8	199	1,767	220.7	1,964	242.7	2,160
2 1/2	63.5	34x19 RRL Gal IWRC Cushion Rope	12.4	18.4	217	1,935	241.6	2,150	265.7	2,365
2 5/8	66.7	34x19 RRL Gal IWRC Cushion Rope	13.4	20.0	236	2,099	262.0	2,332	288.2	2,565
2 3/4	69.9	34x19 RRL Gal IWRC Cushion Rope	14.3	21.2	250	2,229	278.3	2,477	306.1	2,724

This table is for illustration purposes only. Balance ropes are normally custom designed to achieve a desired weight and breaking load which meet individual shaft parameters. Rope construction may also vary to suit loop requirements.

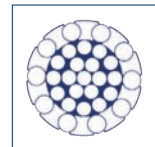

Power-LOC HLC

DIAMETER		ROPE CONSTRUCTION	APPROX. WEIGHT		MINIMUM BREAKING LOAD			
inches	mm		lb/ft	kg/m	Gr 65		Gr 70	
					Tons	kN	Tons	kN
1 1/2	38.1	Power-Loc HLC	5.5	8.1	93	827	102	911
1 5/8	41.3	Power-Loc HLC	6.4	9.6	109	971	120	1,069
1 3/4	44.5	Power-Loc HLC	7.5	11.1	126	1,126	139	1,240
1 7/8	47.6	Power-Loc HLC	8.6	12.7	145	1,292	160	1,424
2	50.8	Power-Loc HLC	9.7	14.5	165	1,470	182	1,620

Power-LOC FLC

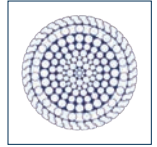

DIAMETER		ROPE CONSTRUCTION	APPROX. WEIGHT		MINIMUM BREAKING LOAD			
inches	mm		lb/ft	kg/m	HS		EHS	
					Tons	kN	Tons	kN
5/8	15.9	Power-Loc FLC Hoist & Sinking Ropes	0.88	1.31	21.9	195	24.6	219
11/16	17.5	Power-Loc FLC Hoist & Sinking Ropes	1.10	1.64	27.6	246	30.4	271
3/4	19.1	Power-Loc FLC Hoist & Sinking Ropes	1.31	1.95	33.0	294	36.3	323
13/16	20.6	Power-Loc FLC Hoist & Sinking Ropes	1.58	2.35	38.3	341	42.1	375
7/8	22.2	Power-Loc FLC Hoist & Sinking Ropes	1.85	2.75	44.7	398	49.1	437
15/16	23.8	Power-Loc FLC Hoist & Sinking Ropes	2.12	3.15	51.1	455	56.2	500
1	25.4	Power-Loc FLC Hoist & Sinking Ropes	2.45	3.65	58.6	522	64.4	573
1 1/16	27.0	Power-Loc FLC Hoist & Sinking Ropes	2.77	4.12	65.6	584	72.2	643
1 1/8	26.8	Power-Loc FLC Hoist & Sinking Ropes	3.08	4.58	74.1	660	81.9	729
1 3/16	30.2	Power-Loc FLC Hoist & Sinking Ropes	3.41	5.07	82.7	736	91.3	813
1 1/4	31.8	Power-Loc FLC Hoist & Sinking Ropes	3.75	5.58	91.2	812	100.6	896
1 5/16	33.3	Power-Loc FLC Hoist & Sinking Ropes	4.13	6.15	100.7	896	111.2	990
1 3/8	34.9	Power-Loc FLC Hoist & Sinking Ropes	4.53	6.74	110.2	981	121.7	1,084
1 7/16	36.5	Power-Loc FLC Hoist & Sinking Ropes	4.95	7.37	120.7	1,074	133.4	1,188
1 1/2	38.1	Power-Loc FLC Hoist & Sinking Ropes	5.40	8.04	131.1	1,167	145.2	1,292
1 9/16	39.7	Power-Loc FLC Hoist & Sinking Ropes	5.74	8.54	142.5	1,268	156.9	1,396
1 5/8	41.3	Power-Loc FLC Hoist & Sinking Ropes	6.24	9.29	153.9	1,370	169.7	1,510
1 11/16	42.9	Power-Loc FLC Hoist & Sinking Ropes	6.75	10.05	166.3	1,480	183.7	1,635
1 3/4	44.5	Power-Loc FLC Hoist & Sinking Ropes	7.29	10.85	178.6	1,590	196.7	1,750
1 13/16	46.0	Power-Loc FLC Hoist & Sinking Ropes	7.84	11.67	191.9	1,708	211.8	1,885
1 7/8	47.6	Power-Loc FLC Hoist & Sinking Ropes	8.46	12.59	205.2	1,826	225.9	2,011
1 15/16	49.2	Power-Loc FLC Hoist & Sinking Ropes	9.06	13.48	219.5	1,954	241.4	2,148
2	50.8	Power-Loc FLC Hoist & Sinking Ropes	9.67	14.39	233.7	2,080	257.5	2,292
2 1/16	52.4	Power-Loc FLC Hoist & Sinking Ropes	10.28	15.30	248.9	2,215	273.9	2,438
2 1/8	54.0	Power-Loc FLC Hoist & Sinking Ropes	10.86	16.16	263.9	2,349	290.3	2,584

PRODUCT SPECIFICATIONS

BREAKING LOAD TABLES - UNDERGROUND MINING

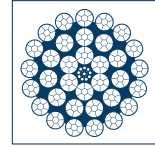

Dy-Pac 34

DIAMETER		CONSTRUCTION	APPROX. WEIGHT		MINIMUM BREAKING LOAD					
inches	mm		lb/ft	kg/m	Gr 120		Gr 125		Gr 133	
					Tons	kN	Tons	kN	Tons	kN
3/4	19	34x7 RLL LCD Dy-Pac WSC	1.10	1.64	29.7	265	31.0	276	33.0	293
7/8	22	34x7 RLL LCD Dy-Pac WSC	1.50	2.23	40.5	360	42.1	375	44.9	399
1	25	34x7 RLL LCD Dy-Pac WSC	1.96	2.92	52.7	469	54.9	489	58.4	520
1 1/8	29	34x7 RLL LCD Dy-Pac WSC	2.48	3.69	68.1	606	70.3	626	75.5	672
1 1/4	32	34x7 RLL LCD Dy-Pac WSC	3.06	4.55	83.4	742	86.8	773	92.4	823
1 3/8	35	34x7 RLL LCD Dy-Pac WSC	3.70	5.51	101	898	105	936	112	995
1 1/2	38	34x7 RLL LCD Dy-Pac WSC	4.40	6.55	116	1,035	121	1,078	129	1,147
1 5/8	41	34x7 RLL LCD Dy-Pac WSC	5.19	7.72	136	1,214	142	1,265	151	1,346
1 3/4	44	34x7 RLL LCD Dy-Pac WSC	6.00	8.93	159	1,411	165	1,469	176	1,564
1 7/8	48	34x7 RLL LCD Dy-Pac WSC	7.22	10.74	182	1,619	190	1,687	202	1,795
2	51	34x7 RLL LCD Dy-Pac WSC	7.83	11.65	197	1,756	205	1,829	219	1,946

PS 620

DIAMETER		ROPE CONSTRUCTION	APPROX. WEIGHT		MINIMUM BREAKING LOAD			
inches	mm		lb/ft	kg/m	Gr 115		Gr 125	
					Tons	kN	Tons	kN
5/8	16	6x19 RLL Polyester Core	0.65	0.97	16.0	142	17.4	155
3/4	19	6x19 RLL Polyester Core	0.92	1.37	22.5	200	24.5	218
7/8	22	6x19 RLL Polyester Core	1.24	1.85	30.2	269	32.9	293
1	25	6x19 RLL Polyester Core	1.60	2.38	39.0	348	42.5	378
1 1/8	29	6x19 RLL Polyester Core	2.15	3.20	52.5	468	57.1	508
1 1/4	32	6x19 RLL Polyester Core	2.62	3.90	64.0	570	69.6	620
1 3/8	35	6x19 RLL Polyester Core	3.14	4.67	76.6	681	83.2	741
1 1/2	38	6x19 RLL Polyester Core	3.70	5.51	90.3	803	98.1	873
1 5/8	41	6x19 RLL Polyester Core	4.30	6.40	105.1	935	114.2	1,016
1 3/4	44	6x19 RLL Polyester Core	4.96	7.38	121.0	1,077	131.6	1,171

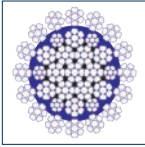

Cushion-Pac 35 High Breaking Load

DIAMETER	CONSTRUCTION	APPROX. WEIGHT	MINIMUM BREAKING LOAD		
			1770 MPa	1960 MPa	2160 MPa
mm		kg/m	kN	kN	kN
26	Cushion-Pac 35 HBL	3.3	510	560	620
28	Cushion-Pac 35 HBL	3.8	600	650	720
30	Cushion-Pac 35 HBL	4.4	680	740	830
32	Cushion-Pac 35 HBL	4.9	780	850	940
34	Cushion-Pac 35 HBL	5.6	880	950	1060
36	Cushion-Pac 35 HBL	6.3	980	1070	1190
38	Cushion-Pac 35 HBL	7.0	1100	1190	1320
40	Cushion-Pac 35 HBL	7.7	1220	1320	1470
42	Cushion-Pac 35 HBL	8.5	1340	1460	1620
44	Cushion-Pac 35 HBL	9.4	1470	1600	1780
46	Cushion-Pac 35 HBL	10.2	1610	1750	1940
48	Cushion-Pac 35 HBL	11.1	1750	1900	2110
50	Cushion-Pac 35 HBL	12.1	1900	2060	2290
52	Cushion-Pac 35 HBL	13.1	2050	2230	2480
54	Cushion-Pac 35 HBL	14.1	2210	2410	2680
56	Cushion-Pac 35 HBL	15.2	2380	2590	2880

DIAMETER	CONSTRUCTION	APPROX. WEIGHT	MINIMUM BREAKING LOAD		
			Gr 115	Gr 125	Gr 140
inches		lb/ft	Tons	Tons	Tons
1	Cushion-Pac 35 HBL	2.1	56.0	60.8	67.6
1 1/8	Cushion-Pac 35 HBL	2.7	70.8	77.0	85.6
1 1/4	Cushion-Pac 35 HBL	3.3	87.4	95.0	106
1 3/8	Cushion-Pac 35 HBL	4.0	106	115	128
1 1/2	Cushion-Pac 35 HBL	4.8	126	137	152
1 5/8	Cushion-Pac 35 HBL	5.6	148	161	178
1 3/4	Cushion-Pac 35 HBL	6.5	171	186	207
1 7/8	Cushion-Pac 35 HBL	7.5	197	214	238
2	Cushion-Pac 35 HBL	8.5	224	243	270
2 1/8	Cushion-Pac 35 HBL	9.6	253	275	305
2 1/4	Cushion-Pac 35 HBL	10.8	283	308	342
2 3/8	Cushion-Pac 35 HBL	12.0	316	343	381
2 1/2	Cushion-Pac 35 HBL	13.3	350	380	422

PRODUCT SPECIFICATIONS

BREAKING LOAD TABLES - UNDERGROUND MINING

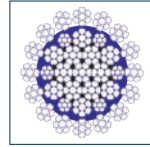

Cushion-Pac 35 Low Weight

DIAMETER	CONSTRUCTION	APPROX. WEIGHT	MINIMUM BREAKING LOAD		
			1770 MPa	1960 MPa	2160 MPa
mm		kg/m	kN	kN	kN
26	Cushion-Pac 35 Low Weight	2.9	440	480	540
28	Cushion-Pac 35 Low Weight	3.4	520	560	620
30	Cushion-Pac 35 Low Weight	3.9	590	640	720
32	Cushion-Pac 35 Low Weight	4.5	670	730	810
34	Cushion-Pac 35 Low Weight	5.0	760	830	920
36	Cushion-Pac 35 Low Weight	5.7	850	930	1030
38	Cushion-Pac 35 Low Weight	6.3	950	1030	1150
40	Cushion-Pac 35 Low Weight	7.0	1050	1150	1270
42	Cushion-Pac 35 Low Weight	7.7	1160	1260	1400
44	Cushion-Pac 35 Low Weight	8.4	1270	1390	1540
46	Cushion-Pac 35 Low Weight	9.2	1390	1510	1680
48	Cushion-Pac 35 Low Weight	10.0	1520	1650	1830
50	Cushion-Pac 35 Low Weight	10.9	1650	1790	1990
52	Cushion-Pac 35 Low Weight	11.8	1780	1940	2150
54	Cushion-Pac 35 Low Weight	12.7	1920	2090	2320
56	Cushion-Pac 35 Low Weight	13.7	2060	2240	2490

DIAMETER	CONSTRUCTION	APPROX. WEIGHT	MINIMUM BREAKING LOAD		
			Gr 115	Gr 125	Gr 140
inches		lb/ft	Tons	Tons	Tons
1	Cushion-Pac 35 Low Weight	1.9	48.5	52.7	58.6
1 1/8	Cushion-Pac 35 Low Weight	2.4	61.4	66.7	74.1
1 1/4	Cushion-Pac 35 Low Weight	3.0	75.8	82.4	91.5
1 3/8	Cushion-Pac 35 Low Weight	3.6	91.7	100	111
1 1/2	Cushion-Pac 35 Low Weight	4.3	109	119	132
1 5/8	Cushion-Pac 35 Low Weight	5.1	128	139	155
1 3/4	Cushion-Pac 35 Low Weight	5.9	149	162	179
1 7/8	Cushion-Pac 35 Low Weight	6.8	171	185	206
2	Cushion-Pac 35 Low Weight	7.7	194	211	234
2 1/8	Cushion-Pac 35 Low Weight	8.7	219	238	264
2 1/4	Cushion-Pac 35 Low Weight	9.7	246	267	296
2 3/8	Cushion-Pac 35 Low Weight	10.8	274	297	330
2 1/2	Cushion-Pac 35 Low Weight	12.0	303	330	366

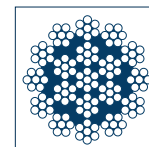

PS 1810 (Shaft Sinking)

DIAMETER		CONSTRUCTION	APPROX. WEIGHT		MINIMUM BREAKING LOAD							
inches	mm		lb/ft	kg/m	Gr 115		Gr 120		Gr 125		Gr 133	
					Tons	kN	Tons	kN	Tons	kN	Tons	kN
3/4	19	18x7 RLL LCD IWRC	0.99	1.47	25.1	224	26.2	234	27.3	243	29.1	259
7/8	22	18x7 RLL LCD IWRC	1.35	2.01	33.7	300	35.2	313	36.6	326	39.0	347
1	25	18x7 RLL LCD IWRC	1.76	2.62	43.6	388	45.5	405	47.4	422	50.5	449
1 1/8	29	18x7 RLL LCD IWRC	2.23	3.32	55.2	491	57.6	512	60.0	534	63.8	568
1 1/4	32	18x7 RLL LCD IWRC	2.8	4.17	67.7	602	70.6	628	73.6	655	78.3	697
1 3/8	35	18x7 RLL LCD IWRC	3.38	5.03	81.7	727	85.2	759	88.8	790	94.5	841
1 1/2	38	18x7 RLL LCD IWRC	4.02	5.98	96.7	861	101	898	105	936	112	996
1 5/8	41	18x7 RLL LCD IWRC	4.69	6.98	113	1,009	118	1,053	123	1,096	131	1,167
1 3/4	44	18x7 RLL LCD IWRC	5.4	8.04	136	1,209	142	1,262	148	1,314	157	1,398
1 7/8	48	18x7 RLL LCD IWRC	6.18	9.20	151	1,342	157	1,400	162	1,437	174	1,552
2	51	18x7 RLL LCD IWRC	7.08	10.54	171	1,522	179	1,589	186	1,655	198	1,761
2 1/8	54	18x7 RLL LCD IWRC	8.19	12.19	198	1,762	207	1,838	215	1,915	229	2,037
2 1/4	57	18x7 RLL LCD IWRC	9.15	13.62	221	1,967	231	2,053	240	2,138	256	2,275
2 3/8	60	18x7 RLL LCD IWRC	10.16	15.12	246	2,185	256	2,280	267	2,375	284	2,527
2 1/2	64	18x7 RLL LCD IWRC	11.22	16.70	271	2,414	283	2,519	295	2,624	314	2,792

PS 1810 (Balance Ropes)

DIAMETER		CONSTRUCTION	APPROX. WEIGHT		MINIMUM BREAKING LOAD					
inches	mm		lb/ft	kg/m	Gr 115		Gr 120		Gr 125	
					Tons	kN	Tons	kN	Tons	kN
3/4	19	18x7 RLL LCD Polyester Core	0.93	1.38	17.6	156	19.5	173	21.5	191
7/8	22	18x7 RLL LCD Polyester Core	1.26	1.88	24.2	216	27.1	241	29.6	264
1	25	18x7 RLL LCD Polyester Core	1.64	2.44	31.8	283	35.2	313	38.9	346
1 1/8	29	18x7 RLL LCD Polyester Core	2.07	3.08	40.4	359	44.7	397	49.3	439
1 1/4	32	18x7 RLL LCD Polyester Core	2.56	3.81	49.4	440	55.1	490	60.4	537
1 3/8	35	18x7 RLL LCD Polyester Core	3.10	4.61	59.9	533	66.5	592	73.2	651
1 1/2	38	18x7 RLL LCD Polyester Core	3.69	5.49	71.3	634	79.3	706	87.1	775
1 5/8	41	18x7 RLL LCD Polyester Core	4.33	6.44	83.6	744	93.1	829	102	909
1 3/4	44	18x7 RLL LCD Polyester Core	5.02	7.47	97.4	867	108	960	119	1,059
1 7/8	48	18x7 RLL LCD Polyester Core	5.76	8.57	112	993	124	1,103	136	1,214
2	51	18x7 RLL LCD Polyester Core	6.56	9.76	127	1,129	141	1,256	155	1,380
2 1/8	54	18x7 RLL LCD Polyester Core	7.40	11.01	143	1,277	159	1,416	175	1,560
2 1/4	57	18x7 RLL LCD Polyester Core	8.30	12.35	161	1,429	178	1,585	196	1,746
2 3/8	60	18x7 RLL LCD Polyester Core	9.25	13.77	179	1,594	199	1,767	219	1,948
2 1/2	64	18x7 RLL LCD Polyester Core	10.25	15.25	198	1,763	220	1,957	242	2,155

PRODUCT SPECIFICATIONS

BREAKING LOAD TABLES - UNDERGROUND MINING

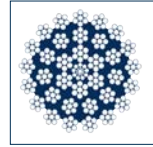

PS 3410 (Shaft Sinking)

DIAMETER		CONSTRUCTION	APPROX. WEIGHT		MINIMUM BREAKING LOAD							
					Gr 115		Gr 120		Gr 125		Gr 133	
inches	mm		lb/ft	kg/m	Tons	kN	Tons	kN	Tons	kN	Tons	kN
3/4	19	34x7 RLL LCD WSC	1.01	1.50	24.9	222	26.0	231	27.1	241	28.8	256
7/8	22	34x7 RLL LCD WSC	1.38	2.05	33.9	301	35.3	315	36.8	328	39.2	349
1	25	34x7 RLL LCD WSC	1.8	2.68	44.2	394	46.1	411	48.1	428	51.1	455
1 1/8	29	34x7 RLL LCD WSC	2.28	3.39	56.0	498	58.4	520	60.9	542	64.8	576
1 1/4	32	34x7 RLL LCD WSC	2.81	4.18	69.1	615	72.1	642	75.1	669	79.9	711
1 3/8	35	34x7 RLL LCD WSC	3.41	5.07	83.6	744	87.3	777	90.9	809	96.7	861
1 1/2	38	34x7 RLL LCD WSC	4.05	6.03	99.5	886	104	924	108	963	115	1,024
1 5/8	41	34x7 RLL LCD WSC	4.76	7.08	117	1,040	122	1,085	127	1,130	135	1,202
1 3/4	44	34x7 RLL LCD WSC	5.52	8.21	135	1,206	141	1,258	147	1,311	157	1,394
1 7/8	48	34x7 RLL LCD WSC	6.33	9.42	156	1,384	162	1,444	169	1,505	180	1,601
2	51	34x7 RLL LCD WSC	7.21	10.73	177	1,575	185	1,643	192	1,712	205	1,821
2 1/8	54	34x7 RLL LCD WSC	8.13	12.10	200	1,778	208	1,855	217	1,932	231	2,056
2 1/4	57	34x7 RLL LCD WSC	9.12	13.57	224	1,993	234	2,080	243	2,167	259	2,305
2 3/8	60	34x7 RLL LCD WSC	10.16	15.12	250	2,221	260	2,317	271	2,414	289	2,568
2 1/2	64	34x7 RLL LCD WSC	11.26	16.76	276	2,461	289	2,568	301	2,675	320	2,846

PS 3410 (Balance Ropes)

DIAMETER		CONSTRUCTION	APPROX. WEIGHT		MINIMUM BREAKING LOAD					
					Gr 115		Gr 120		Gr 125	
inches	mm		lb/ft	kg/m	Tons	kN	Tons	kN	Tons	kN
3/4	19	34x7 RLL LCD Polyester Core	0.94	1.40	18.1	161	20.0	178	22.1	196
7/8	22	34x7 RLL LCD Polyester Core	1.28	1.90	24.7	220	27.6	245	30.2	269
1	25	34x7 RLL LCD Polyester Core	1.68	2.50	32.3	288	35.6	317	39.5	351
1 1/8	29	34x7 RLL LCD Polyester Core	2.12	3.15	40.4	359	45.1	402	49.3	439
1 1/4	32	34x7 RLL LCD Polyester Core	2.62	3.90	50.4	448	56.1	499	61.5	548
1 3/8	35	34x7 RLL LCD Polyester Core	3.17	4.72	60.8	541	67.5	600	74.3	661
1 1/2	38	34x7 RLL LCD Polyester Core	3.77	5.61	72.2	643	80.3	714	88.2	785
1 5/8	41	34x7 RLL LCD Polyester Core	4.42	6.58	84.6	753	94.5	841	103	920
1 3/4	44	34x7 RLL LCD Polyester Core	5.13	7.63	98.3	875	109	972	120	1,070
1 7/8	48	34x7 RLL LCD Polyester Core	5.89	8.77	113	1,002	125	1,116	138	1,225
2	51	34x7 RLL LCD Polyester Core	6.70	9.97	128	1,141	143	1,272	157	1,395
2 1/8	54	34x7 RLL LCD Polyester Core	7.57	11.27	145	1,289	162	1,437	177	1,576
2 1/4	57	34x7 RLL LCD Polyester Core	8.48	12.62	162	1,446	181	1,611	199	1,767
2 3/8	60	34x7 RLL LCD Polyester Core	9.45	14.06	181	1,611	201	1,792	221	1,969
2 1/2	64	34x7 RLL LCD Polyester Core	10.47	15.58	200	1,784	223	1,987	245	2,180

CONTACTS

Head Office

5501 Trans-Canada Highway
Pointe-Claire, Quebec
H9R 1B7 Canada

Tel: 514.697.9711
Fax: 514.697.3534
Toll free: 1.800.565.5501

General & Sales Inquiries

mail@wirerope.com

For Sales Representatives and Distributors in Canada, USA,
and South America, please visit the CONTACT section of
our website at www.wirerope.com

www.wirerope.com